

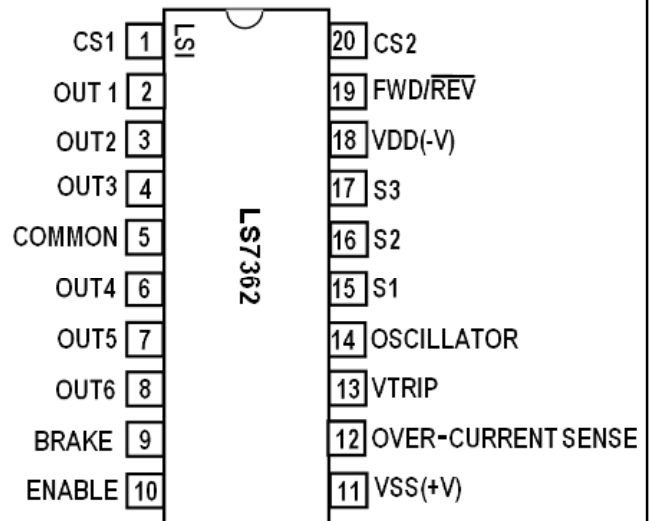
## BRUSHLESS DC MOTOR COMMUTATOR / CONTROLLER

Nov2015

### FEATURES:

- Speed control by Pulse Width Modulating (PWM) only the low-side drivers reduces switching losses in level converter circuitry for high voltage motors.
- Open or closed loop motor speed control.
- +5V to +28V operation ( $V_{SS} - V_{DD}$ ).
- Externally selectable input to output code for 60°, 120°, 240°, or 300° electrical sensor spacing.
- Three or four phase operation.
- Analog speed control.
- Forward/Reverse control.
- Output enable control
- Positive static braking
- Over-current sensing
- Six outputs drive switching bridge directly.
- **LS7362** (DIP), **LS7362-S** (SOIC)
- **LS7362-TS** (TSSOP) – See connection diagram

### PIN ASSIGNMENT – TOP VIEW



### DESCRIPTION:

The **LS7362** is a MOS integrated circuit designed to generate the signals necessary to control a three phase or four phase brushless DC motor. It is the basic building block of a brushless DC motor controller. The circuits respond to changes at the SENSE inputs, originating at the motor position sensors, to provide electronic commutation of the motor windings. Pulse width modulation (PWM) of low-side drivers for motor speed control is accomplished through the VTRIP input (Analog speed control) in conjunction with the OSCILLATOR input. Over-current circuitry is provided to protect the windings, associated drivers, and power supply. The **LS7362** circuitry causes the external output drivers to switch off immediately upon sensing the over-current condition, and on again only when the over-current condition disappears and the positive edge of the saw-tooth OSCILLATOR occurs. This limits the over-current sense cycling to the chopping rate of the saw-tooth OSCILLATOR. A positive braking feature is provided to effect rapid deceleration. The **LS7362** is designed for driving Bipolar and Field Effect Transistors. Because only low-side drivers are pulse-width modulated, the **LS7362** is ideally suited in situations where the integrated circuit interfaces with level converters to drive high voltage brushless DC motors. By pulse width modulating the low-side drivers only, the switch losses in the level conversion circuitry for the high-side drivers is minimized. Figure 1 indicates how the level conversion is accomplished.

The COMMON, Pin 5, is tied to the positive supply rail and **LS7362** Outputs 1, 2, and 3 are used to drive level converters Q101, Q102 and Q103, respectively. Only the motor top side drivers consisting of Q107, Q108 and Q109 which are connected to the motor power supply,  $V_M$ , will be subject to the high speed switching currents that flow through the motor. The level converters are turned on and off at the slower commutation rate.

### INPUT / OUTPUT DESCRIPTION:

#### COMMUTATION SELECTS (Pins 1, 20)

These inputs are used to select the proper sequence of outputs based on the electrical separation of the motor position sensors. With both inputs low (logic zero), the sequence is adjusted for 60° electrical separation, with CS2 high and CS1 low 120° separation sequence is selected, with CS1 high and CS2 low 240° separation sequence is selected and with CS1 and CS2 high the 300° separation sequence is selected. Note that in all cases the external output drivers are disabled for invalid SENSE input codes. Internal pull down resistors are provided at Pins 1 and 20 causing a logic zero when these pins are left open.

**FORWARD/REVERSE** (Pin 19)

This pin acts to modify the input to output sequence such that when brought from high to low or low to high the direction of rotation will reverse. An internal pull up resistor is provided at Pin 19 causing a logic one when left open.

**SENSE INPUTS** (Pins 15, 16, 17)

These inputs provide control of the output commutation sequence as shown in Table III. S1, S2, S3 originate in the position sensors of the motor and must sequence in cycle code order. Hall switch "pull-up" resistors are provided at Pins 15, 16 and 17. The positive supply of the Hall devices should be common to the chip V<sub>SS</sub>.

**BRAKE** (Pin 9)

A high level applied to this input unconditionally turns off outputs 1, 2 and 3 and turns on outputs 4,5 and 6 (See Figure 1). Transistors Q101, Q102 and Q103 cut off causing Q107, Q108 and Q109 to cut off and transistors Q104, Q105 and Q106 turn on, shorting the windings together. The BRAKE has priority over all other inputs. An internal pull down resistor is provided at Pin 9 causing no braking when left open. (Center-tapped motor configuration requires a power supply disconnect transistor controlled by the BRAKE signal - See Figure 3.)

**ENABLE** (Pin 10)

A high level on this input permits the output to sequence as in Table III, while a low disables all external output drivers. An internal "pull up" resistor is provided at Pin 10, enabling when left open. Positive edges at this input will reset the over-current flip-flop. When the VTRIP input (Pin 13) is connected to V<sub>DD</sub> and the OSCILLATOR input (Pin 14) is tied to V<sub>SS</sub>, the ENABLE input can be used for PWM Output drive. In this configuration, PWM is applied to all Output drivers.

**OVERCURRENT SENSE** (Pin 12)

This input provides the user a way of protecting the motor winding, drivers and power supply from an overload condition. The user provides a fractional ohm resistor between the negative supply and the common emitters of the NPN drivers. This point is connected to one end of a potentiometer (e.g. 100k Ohms), the other end of which is connected to the positive supply. The wiper pickoff is - adjusted so that all outputs are disabled for currents greater than the limit. The action of the input is to disable all external output drivers. When BRAKE exists, OVER-CURRENT SENSE will be overridden. The over-current circuitry latches the over-current condition. The latch may be reset by the positive edge of either the saw-tooth OSCILLATOR or the ENABLE input. When using the ENABLE input as a chopped input, the OSCILLATOR pin should be held at V<sub>SS</sub>. When the ENABLE input is held high, the OSCILLATOR must be used to reset the over-current latch.

**VTRIP** (Pin 13)

This pin is used in conjunction with the saw-tooth OSC input. When the voltage level applied to VTRIP is more negative than the waveform at the OSC input, the low-side drivers will be enabled as shown in Table 3. When VTRIP is more positive than the saw-tooth OSC waveform the low side drivers are disabled. The saw-tooth waveform at the OSC input typically varies from 0.55V<sub>SS</sub> to V<sub>SS</sub> - 2V. The purpose of

the VTRIP input in conjunction with the OSCILLATOR is to provide variable speed adjustment for the motor by means of PWM of the low-side drivers for V<sub>SS</sub> greater than 7V. Below V<sub>SS</sub> = 7V, the IC may only be used as a commutator. (See Note).

**Note:** Below V<sub>SS</sub> = 7V, the OSC saw-tooth amplitude is too small to allow proper operation of the PWM circuitry.

**OSCILLATOR** (Pin 14)

A resistor and capacitor connected to this pin (See Fig. 6) provide the timing components for a saw-tooth OSCILLATOR. The signal generated is used in conjunction with VTRIP to provide PWM for variable speed applications and to reset the over-current condition.

**OUTPUTS 1, 2, 3** (Pin 2, 3, 4)

These open drain outputs are enabled as shown in Table III and provide base current when the COMMON (Pin 5) is tied to V<sub>SS</sub>. These outputs provide commutation only for the high-side drivers. They are not pulse width modulated to control speed.

**OUTPUTS 4, 5, 6** (Pin 6, 7, 8)

These open drain outputs are enabled as in Table III and provide base current to NPN transistors when the COMMON is tied to V<sub>SS</sub>. They provide commutation and are pulse width modulated to provide speed control.

**COMMON** (Pin 5)

The COMMON is connected to V<sub>SS</sub> for driving low-side drivers and high-side level converters.

**V<sub>SS</sub>, V<sub>DD</sub>** (Pins 11, 18)

Supply voltage positive and negative terminals.

**TYPICAL CIRCUIT OPERATION:**

Figure 1 indicates an application using bipolar power transistors. The oscillator is used for motor speed control as explained under VTRIP. Only low-side drive transistors are pulse width modulated during speed control. The outputs turn on in pairs (See Table III). For example, two separate paths are turned on when Q8 and Q4 are on. One path is from the positive supply through Q8, R1 and the base emitter junction of Q101. The second is from the positive supply through Q4, R14, the base emitter junction of Q105 and the fractional ohm resistor to ground. The current in the first path is determined by the power supply voltage, the impedance of Q8, the value of R1 and the voltage drop across the base-emitter junction of Q101 (0.7V for a single transistor or 1.4V for a Darlington Transistor). The current in the second path is determined by the power supply voltage, the impedance of Q4, the value of R14 and the voltage drop across the base-emitter junction of Q105. Table I provides the recommended value for R1; R2, R3, R13, R14, and R15 are the same value.

Figure 2 indicates an application where Power FETs are used. The nominal power supply for the **LS7362** in this configuration is 15V so that the low side N channel Power FET drivers will have 15V of gate drive. Resistors R8, R10 and R12 are the gate capacitance discharge resistors. Table II indicates the minimum value of R13(=R14=R15) needed as a function of output drive voltage for the low-side drivers.

**MAXIMUM RATINGS:**

PARAMETER	SYMBOL	VALUE	UNIT
DC Supply Voltage	V <sub>SS</sub> - V <sub>DD</sub>	+35	V
AnyInput Voltage to V <sub>SS</sub>	V <sub>IN</sub>	-30 to +0.5	V
Storage Temperature	T <sub>STG</sub>	-65 to +150	°C
Operating Temperature	T <sub>A</sub>	-40 to +125	°C

**DC ELECTRICAL CHARACTERISTICS:**

(All Voltages Referenced to V<sub>DD</sub>, T<sub>A</sub> = 25°C unless otherwise specified)

	SYMBOL	MIN	TYP	MAX	UNIT
Supply Voltage	V <sub>SS</sub>	5	-	28	V
Supply Current (Excluding Outputs)	I <sub>DD</sub>	-	4.5	6	mA
<b>Input Specifications :</b> BRAKE, ENABLE, CS1, CS2 S1, S2, S3, FORWARD/REVERSE	R <sub>IN</sub>	-	150	-	kΩ
Voltage (Logic 1)	V <sub>IH</sub>	V <sub>SS</sub> - 1.5	-	V <sub>SS</sub>	V
(Logic 0)	V <sub>IL</sub>	0	-	V <sub>SS</sub> - 4.0	V
<b>OVERCURRENT SENSE (See Note)</b> Voltage (Logic 1)	V <sub>IH</sub>	(V <sub>SS</sub> /2) + 0.25	-	V <sub>SS</sub>	V
(Logic 0)	V <sub>IL</sub>	0	-	(V <sub>SS</sub> /2) - 0.25	V
<b>Oscillator:</b> Frequency Range	F <sub>osc</sub>	0	2/RC	100	kHz
External Resistor Range	R <sub>osc</sub>	22	-	1000	kΩ

**NOTE:** Theoretical switching point of the OVERCURRENT SENSE input is one half of the power supply determined by an internal bias network in manufacturing. Tolerances cause the switching point to vary plus or minus 0.25V. After manufacture, the switching point remains fixed within 10mV over time and temperature. The input switching sensivity is a maximum of 50mV. There is no hysteresis on the OVERCURRENT SENSE input.

**TABLE I**

OUTPUT CURRENT LIMITING RESISTOR SELECTION TABLE

POWER SUPPLY (Volts)	OUTPUT CURRENT							Resistance (kΩ)
	20	15	10	7.5	5	2.5	mA	
6	.02	.15	.35	.52	.86	1.93		
9	.25	.38	.67	.95	1.5	3.14		
12	.42	.61	.98	1.36	2.09	4.34		
15	.57	.81	1.28	1.76	2.7	5.55		
18	.72	1.02	1.60	2.16	3.3	6.77		
21	.87	1.20	1.89	2.56	3.94	7.96		
24	1.02	1.40	2.19	2.97	4.5	9.18		
28	1.22	1.70	2.58	3.49	5.32	10.7		

**TABLE II**

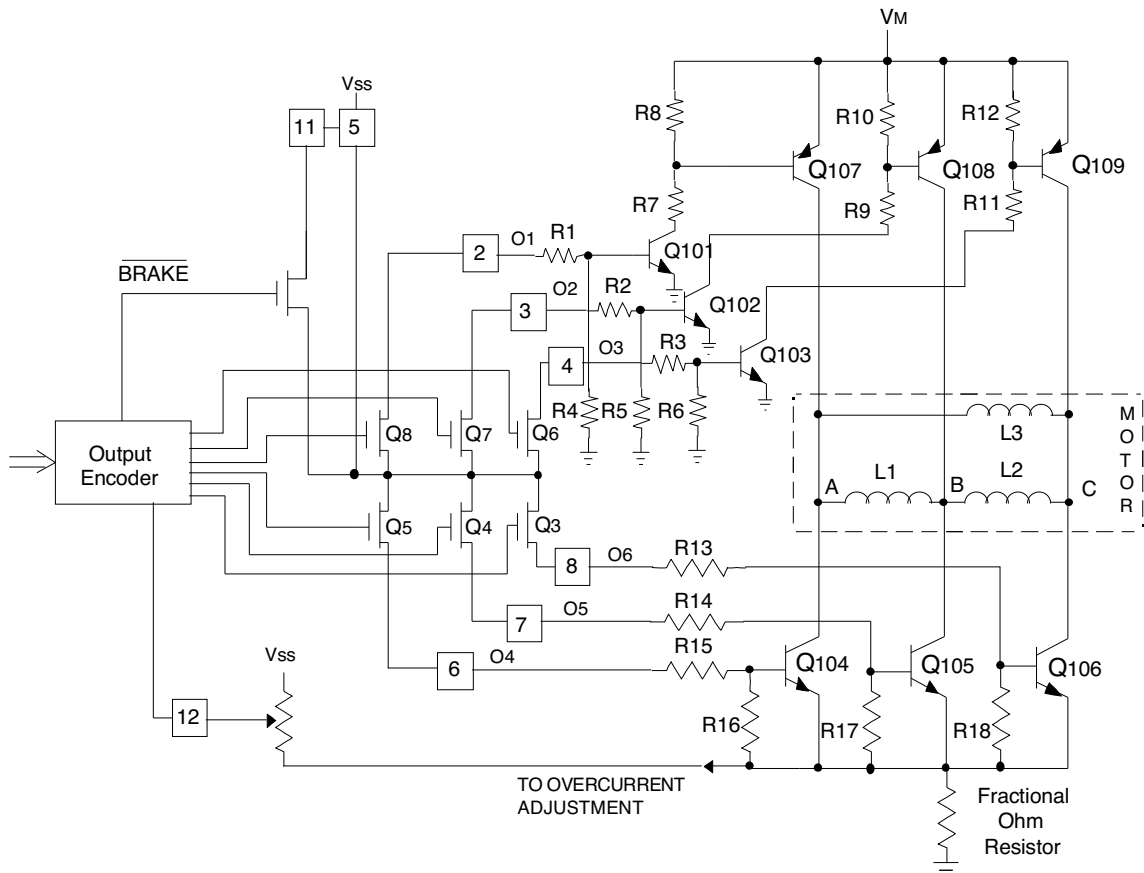
For Power Supply 5 - 28 Volts

R13 (k Ohms)	Output Voltage
10	V <sub>SS</sub> - 0.5
4.0	V <sub>SS</sub> - 1.0
2.0	V <sub>SS</sub> - 2.0

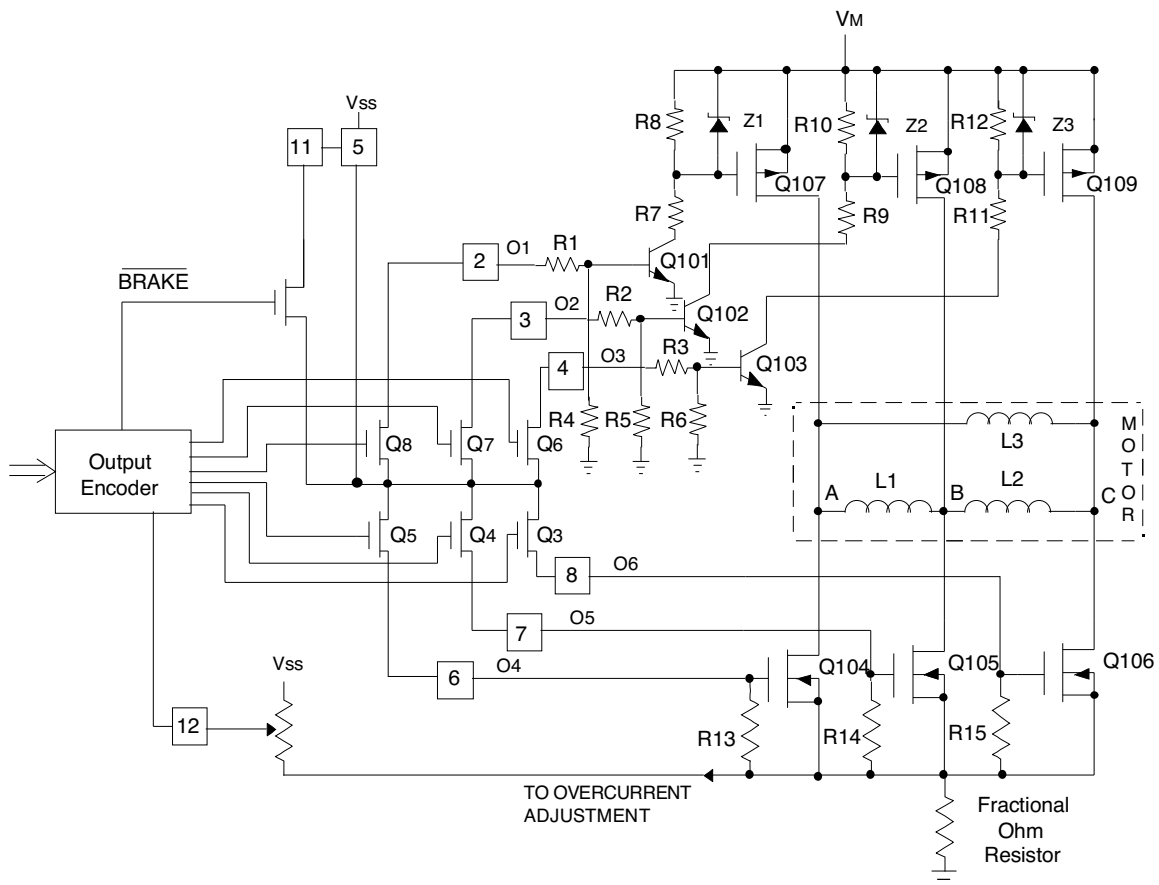
**TABLE III**  
OUTPUT COMMUTATION SEQUENCE  
THREE PHASE OPERATION

SEQUENCE SELECT	CS1 CS2		CS1 CS2		CS1 CS2		CS1 CS2		FORWARD/REVERSE = 1			FORWARD/REVERSE = 0								
	0	0	0	1	1	0	1	1	OUTPUTS	DRIVERS		OUTPUTS	DRIVERS							
ELECTRICAL SEPARATION SENSE INPUTS	S1	S2	S3	S1	S2	S3	S1	S2	S3	ENABLED	A	B	C	ENABLED	A	B	C			
	0	0	0	0	0	1	0	1	0	0	1	1	O1, O5	+	-	Off	O2, O4	-	+	Off
	1	0	0	1	0	1	1	0	1	1	1	O3, O5	Off	-	+	O2, O6	Off	+	-	
	1	1	0	1	0	0	1	0	1	1	0	O3, O4	-	Off	+	O1, O6	+	Off	-	
	1	1	1	1	1	0	1	0	0	0	0	O2, O4	-	+	Off	O1, O5	+	-	Off	
	0	1	1	0	1	0	0	0	0	0	0	O2, O6	Off	+	-	O3, O5	Off	-	+	
	0	0	1	0	1	1	0	0	0	1	O1, O6	+	Off	-	O3, O4	-	Off	+		
	0	1	0	0	0	0	0	0	0	1	0	ALL DISABLED			ALL DISABLED					
	1	0	1	1	1	1	1	0	1	0	1	ALL DISABLED			ALL DISABLED					

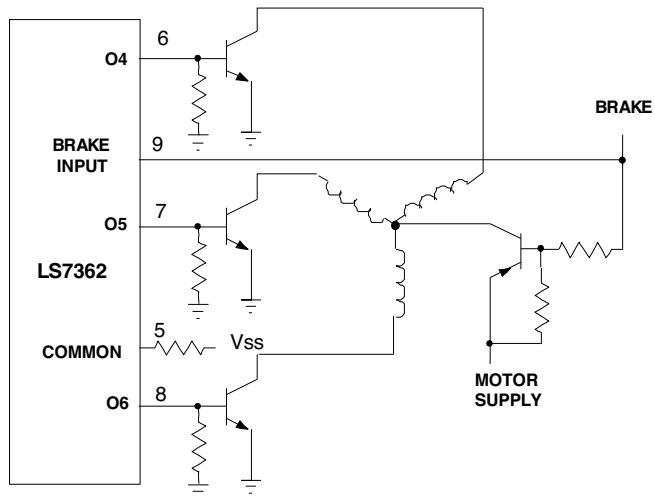
The OVERCURRENT input (BRAKE low) enables external output drivers in normal sequence when more negative than V<sub>SS</sub>/2 and disables all external output drivers when more positive than V<sub>SS</sub>/2. The OVERCURRENT is sensed continuously, and sets a flip flop which is reset by the rising edge of the ENABLE input or the sawtooth OSCILLATOR. (See description under OVERCURRENT SENSE.)



**FIGURE 1. BIPOLAR THREE PHASE OUTPUT DRIVER CIRCUITRY**

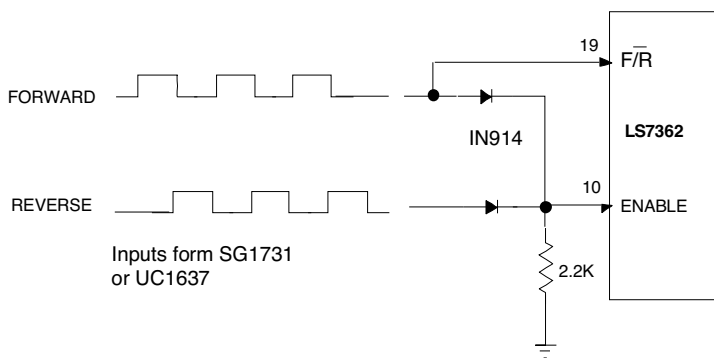


**FIGURE 2. POWER FET THREE PHASE OUTPUT DRIVER CIRCUITRY**



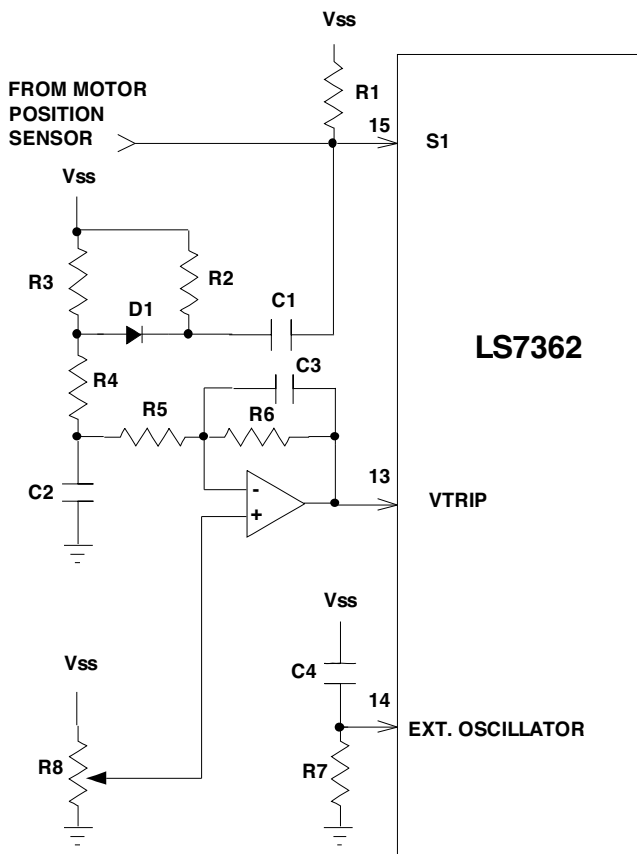
**FIGURE 3.  
SINGLE-ENDED  
DRIVER CIRCUIT**

This configuration requires only one base current limiting resistor connected from the COMMON pin to Vss.



**FIGURE 4. PRECISION CONTROL  
BRUSHLESS DC MOTOR DRIVE**

For controlled acceleration and deceleration of motors in the forward or reverse directions, a motor control pulse width modulator circuit such as the SG1731 or UC1637 can be interfaced with the LS7362. The logical OR gate made up of the resistor-diode network permits the LS7362 to be enabled when either the forward or reverse input is high. By applying the forward input directly to Pin 19, the motor can only operate in the forward direction when the forward input is high and only in the reverse direction when the reverse input is high. Motor direction is determined by relative pulse widths of the forward and reverse inputs while acceleration or deceleration is determined by variations of these widths.



**FIGURE 5  
CLOSED-LOOP SPEED CONTROLLER**

A closed loop system can be configured by differentiating one of the motor position sense inputs and integrating only the negative pulses to form a DC voltage that is applied to the inverting input of an op-amp. The non-inverting input voltage is adjusted with a potentiometer until the resultant voltage at V TRIP causes the motor to run at desired speed. The R2-C1 differentiator, the R3-D1 negative pulse transmitter and the R4-C2 integrator form a frequency to voltage converter. An increase in motor speed above the desired speed causes V TRIP to increase which lowers the duty cycle modulation of the oscillator and the resultant motor speed. A decrease in speed lowers V TRIP and raises the duty cycle modulation and the resultant motor speed. For proper operation, both R5 and R6 should be greater than R4, and R4 in turn should be greater than both R2 and R3. Also the R4-C2 time constant should be greater than the R2-C1 time constant. C3 may be added across R6 for additional V TRIP smoothing.

The information included herein is believed to be accurate and reliable. However, LSI Computer Systems, Inc. assumes no responsibilities for inaccuracies, nor for any infringements of patent rights of others which may result from its use.  
This datasheet has updated specifications.

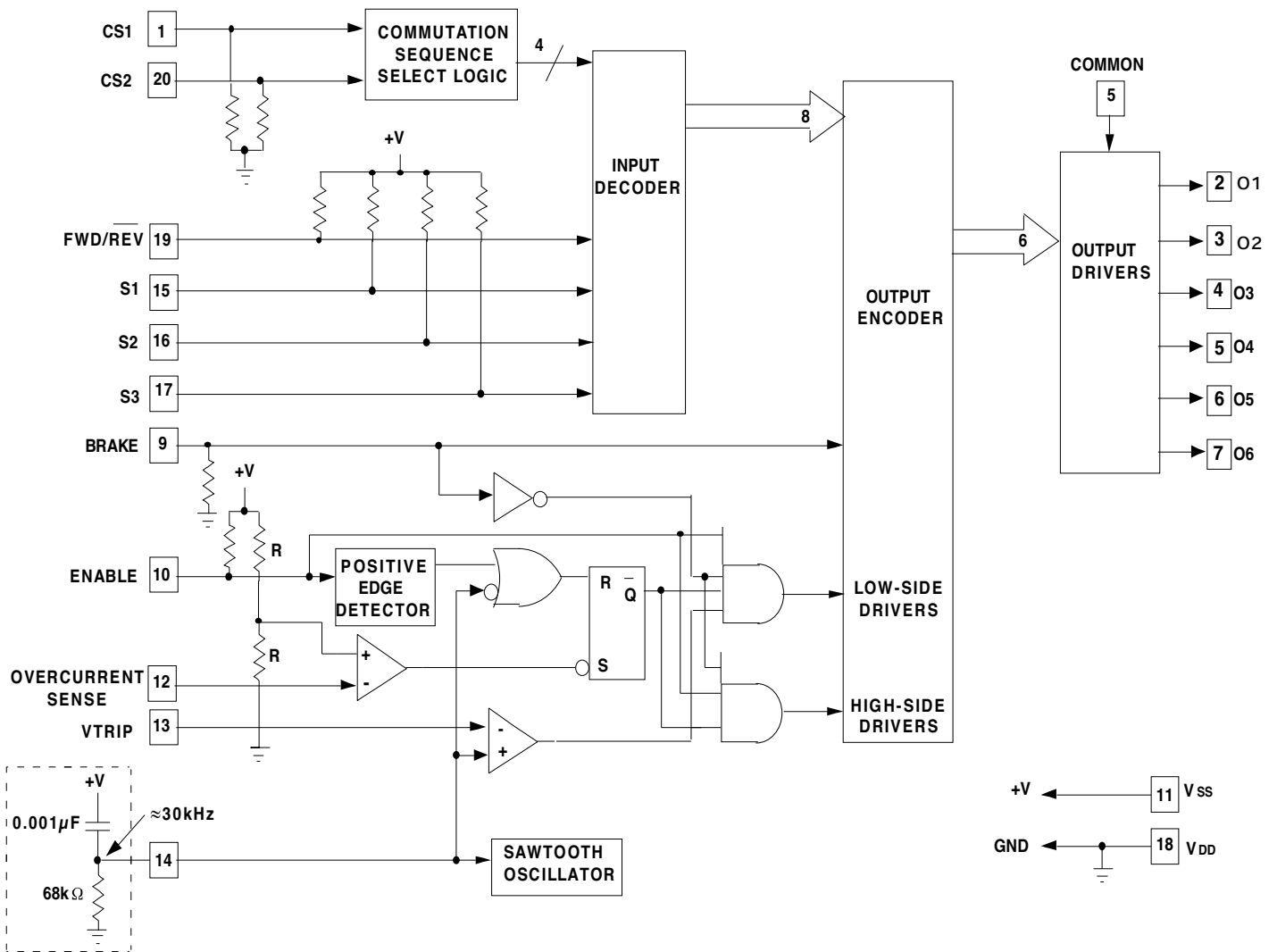


FIGURE 6. LS7362 BLOCK DIAGRAM